

- Coffret réserve de clé rouge/vert/blanc
- Rood/groen/wit kastje voor reserve sleutels
- Break glass key box : red/green-white
- Schlüsselaufbewahrungskasten rot/grün/weiss
- Cofre para llaves, rojo/verde/blanco
- Cassetta per chiave di riserva rossa/verde/blanca
- Quadro de reserva de chaves vermelho/verde/branco

380 54/55/56

**legrand**<sup>®</sup>

NT 65 489 / 00

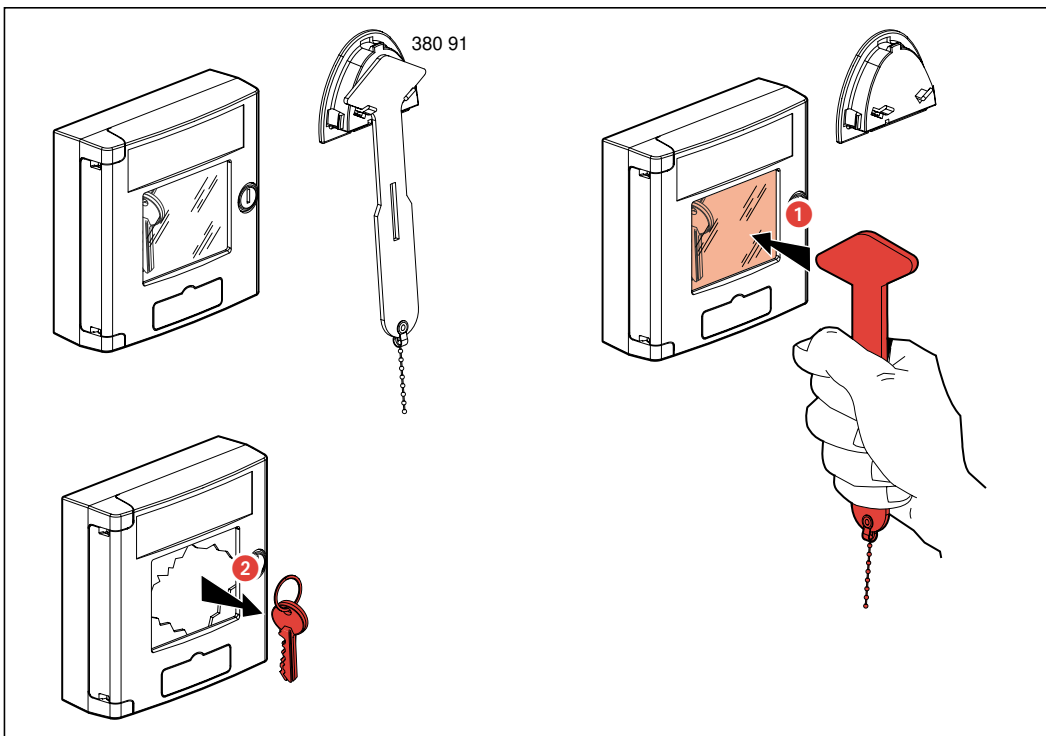
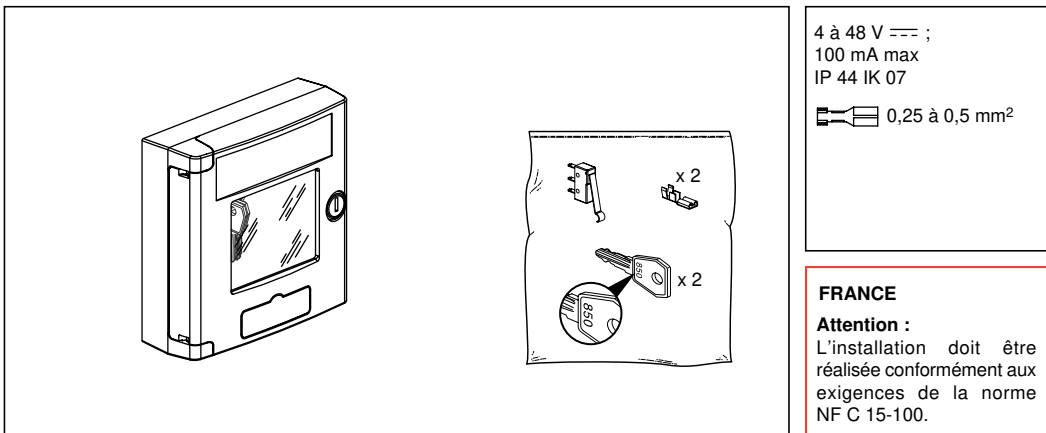

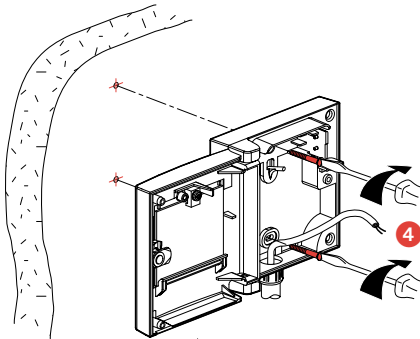
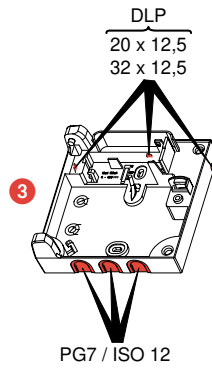
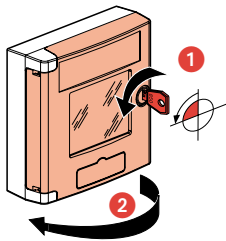

- ou
- of
- or
- oder
- ó
- o

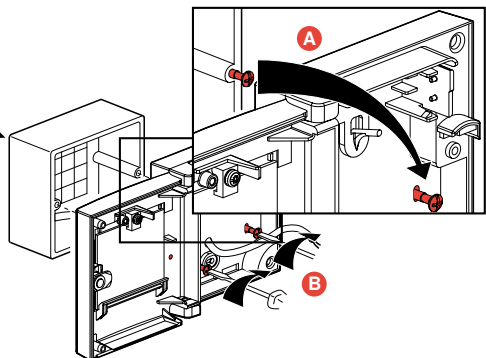
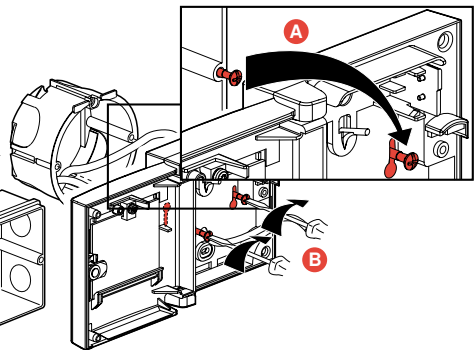
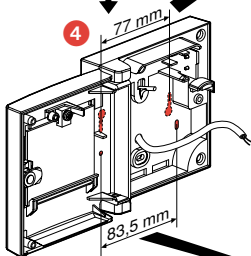

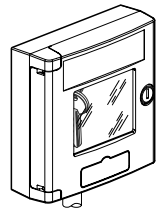
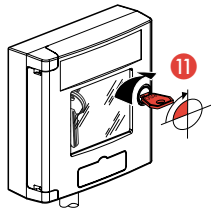
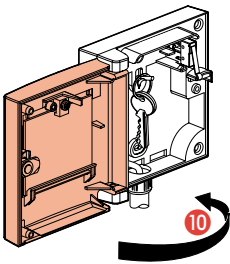
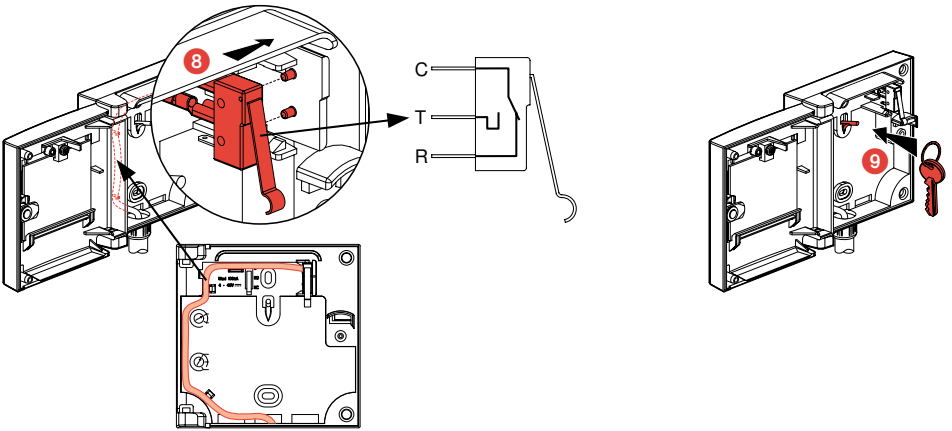
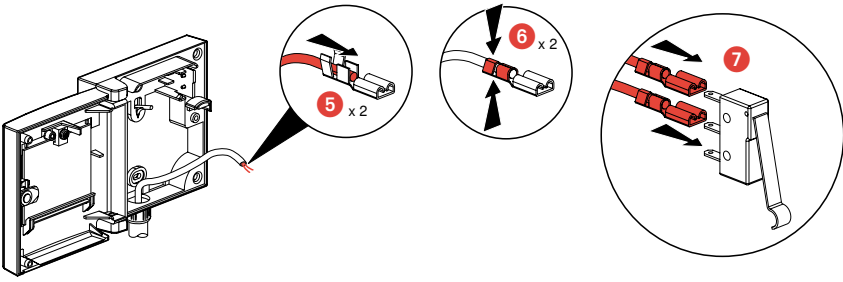

- Remplacement de la vitre
- Vervanging van het glas
- Replacement of glass

- Austausch der Scheibe
- Sustitución del cristal
- Sostituzione del vetro

- Substituição do vidro

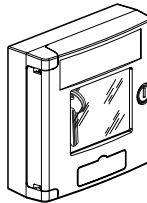
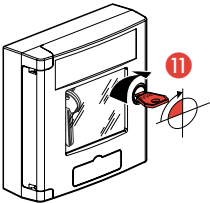
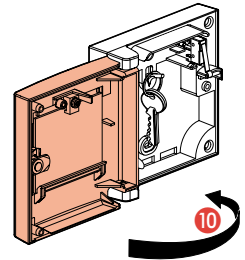
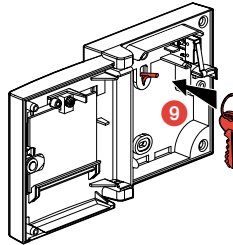
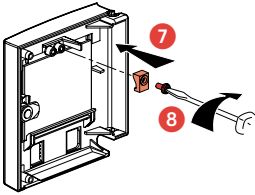
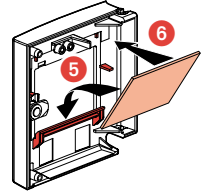
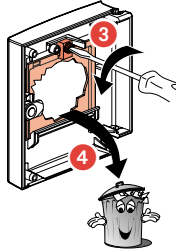
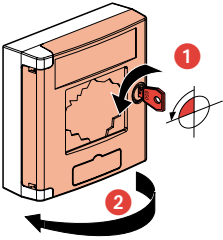

- Raccordement à une alarme technique
- Aansluiting aan een technisch alarm
- Connection to alarm system
- Anschluss an ein Störmeldesystem

- Conexión a una alarma técnica
- Collegamento ad un allarme tecnico
- Ligação a alarme técnico

230 V~ / 12 V~ ou ---

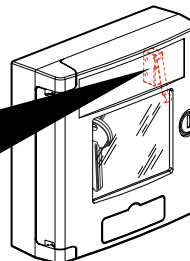
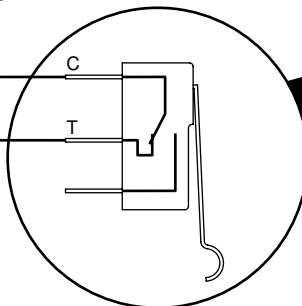
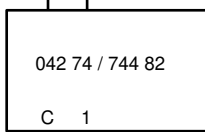

- Vitre intacte
- Onbeschadigd glas
- Glass intact
- Unbeschädigte Scheibe
- Cristal intacto
- Vetro intatto
- Vidro intacto